



True View® 515  
Frequently Asked Questions  
Revision 210419-01

Table of Contents

	Page
<b><u>True View 515 – The System .....</u></b>	<b><u>2</u></b>
<b><u>3D Imaging Sensor vs. Traditional LIDAR/Camera Combinations .....</u></b>	<b><u>5</u></b>
<b><u>System Specifications, Data Outputs .....</u></b>	<b><u>8</u></b>
<b><u>Positioning Strategies and Accuracy .....</u></b>	<b><u>12</u></b>
<b><u>Sensor Calibration .....</u></b>	<b><u>16</u></b>
<b><u>Mission Characteristics .....</u></b>	<b><u>18</u></b>
<b><u>sUAS (drone) Platforms .....</u></b>	<b><u>20</u></b>
<b><u>True View Purchased Systems .....</u></b>	<b><u>22</u></b>
<b><u>True View Subscription Model .....</u></b>	<b><u>24</u></b>
<b><u>Training .....</u></b>	<b><u>28</u></b>
<b><u>True View Ecosystem .....</u></b>	<b><u>29</u></b>

## True View 515 – The System

### 1. What is the True View 515?

The True View 515 is a compact 3D Imaging Sensor (“3DIS”) designed for small Unmanned Aerial Systems (sUAS or drone). It comprises a laser scanner with dual photogrammetric cameras that have been carefully configured to provide a fused LIDAR/imagery field of view (FOV). The system includes full post-processing software that generates a ray-traced 3D colored point cloud (hence the name “3D Imaging Sensors”) and geocoded images.



**Figure 1: True View 515**

### 2. What is in the box?

The True View 515 sensor kit includes:

- True View 515 sensor with PandarXT-32 laser scanner and dual 20 MP photogrammetric cameras
- True View 515 System Control box with cable
- GNSS antenna with cable
- Two RRC-2054 batteries
- RRC-2054 battery charger
- 128 GB USB memory stick (“UMS”) for data storage



- Two 32 GB SD cards (one for each camera)
- Heavy duty “Pelican-style” hard case
- POSPac UAV software (cloud version for subscription systems)
- True View EVO post-processing software

### 3. What is the system warranty?

Warranty actually refers to the idea that we will not leave you stuck with a defective system (which we won’t, of course!). What you are probably most concerned with is the system *Maintenance* programs.

The maintenance program depends on the business model:

- Purchased System include: 1-year parts and labor on hardware. 1-year full software support (all updates as well as email technical support) on POSPac and True View Evo. Customer is responsible for shipping expenses.
- Subscription System – The subscription business model (described in a separate section of this FAQ) is an “evergreen” model that includes all software and hardware updates for the duration of the subscription.

Damage due to abuse or crashes is not covered in either model.

The maintenance program for purchased systems includes:

- 1-year parts and labor on hardware. Customer is responsible for shipping charges and insurance
- 1-year full software support (all updates as well as email technical support) on POSPac and True View Evo
- Hosting support for Calibration files in True View Reckon
- Metered (pay-per-use) access to Applanix SmartBase and Trimble PP-RTX

### 4. How do I purchase a True View 515?

Contact us at [trueview@geocue.com](mailto:trueview@geocue.com). We will either directly engage with you or, if you are in a region served by a GeoCue reseller, put you in touch with the correct True View system reseller.

### 5. Where is the system designed and manufactured?

True View 3D imaging Sensors are designed and manufactured in our Huntsville, Alabama, USA facilities.



6. What electrical/telemetry connections are maintained between the flight platform (sUAS, drone) and the True View 515 sensor?

The True View 515 is self-contained, powered from an internal battery. It has no electrical power or signal connections to the sUAS. This gives you flexibility in selecting a drone that is optimized for your particular collection scenarios.

7. Are there any restrictions on where the system can be shipped?

The True View 515 does not contain any components that cause it to be International Traffic in Arms Regulations (ITAR) restricted. It can be shipped to any country that is not USA trade denied.

8. What are True View Points?

Many add-on services offered for True View sensors are monetized via True View Points (TVP) rather than Dollars or Euros. We use this “virtual currency” method for a variety of reasons such as automating our Subscription model. True View Points are the monetization method for all services provided via our True View Reckon (an Amazon Web Services portal that supports True View systems) cloud services function. The cost of a True View Point is around 1 US dollar, but varies depending on how they are obtained.

## **3D Imaging Sensor vs. Traditional LIDAR/Camera Combinations**

### 1. What is a 3D imaging Sensor (3DIS)?

A 3D Imaging Sensor (3DIS) is a definition coined by us (GeoCue Group Inc.) Basically, it is a system of hardware and software that can generate a true 3D colorized point cloud.

A general 3DIS derives geometric information (X, Y, Z, time) and some target characteristic information (infrared reflectance, for example) from a laser scanner (or radar) and radiometric information from calibrated, synchronized photogrammetric cameras. The laser (or radar) points are “painted” from the synchronized images using a 7 degree of freedom (7 DOF – X, Y, Z, Pitch, Yaw, Roll, Time) ray tracing algorithm.

The camera(s) must be synchronized to the Position and Orientation System (POS) such that the full orientation for each image frame can be computed. This means the system must be encoding time-synchronized camera pitch, yaw and roll in addition to the X, Y, Z location of the camera focal point. These data tuples are called the full, time synchronized Exterior Orientation (EO) of the camera.

Post-processing software must include *ray tracing* algorithms that trace each 3D LIDAR (or radar) point back to the appropriate source image (not a derived image such as an orthophoto). This process requires both the aforementioned camera EO as well as precise camera calibration.

### 2. What is the advantage of the 3D Imaging Sensor compared to a standard LIDAR system?

Data from a standard LIDAR system can be used to generate a 3D monochromatic point cloud. Attributes of the point cloud typically include:

- X, Y, Z position in an exploitation spatial reference system (SRS)
- High resolution GPS time of pulse
- Intensity of the laser return
- Return number (if your LIDAR is multiple return capable)
- Scan angle (angle of the beam relative to nadir when this point was detected)
- Flight line (swath) ID

Note that no color (or, in general, radiometric) information is contained in the above information. A 3D imaging sensor (3DIS) includes both a laser scanner and one or more synchronized photogrammetric cameras (the True View 515 includes two Red-Green-Blue photogrammetric cameras). The system is designed to achieve a coincident field of view (FOV) from all sensors. Post-processing software colorizes the points from the

camera imagery to add, in the case of the True View 515, Red-Green-Blue (RGB) values for each LIDAR point. Note that the camera system in a 3DIS is not restricted to RGB cameras.

3. Is a LIDAR with a third-party add-on camera (such as a Sony Alpha 7) essentially a 3D imaging Sensor (3DIS)?

It can be, but most are not. The camera must be synchronized to the Position and Orientation System such that the full orientation for each image frame can be computed. This means the system must be encoding time-synchronized camera pitch, yaw and roll in addition to the X, Y, Z location of the camera focal point. This is called the full, time synchronized Exterior Orientation (EO) of the camera.

Post-processing software must include *ray tracing* algorithms that trace each 3D LIDAR point back to the appropriate source image. This process requires both the aforementioned camera EO as well as precise camera calibration (precise camera calibration is referred to as camera Interior or Intrinsic Orientation, IO).

Many “strap-on” LIDAR/Camera systems expect you to process the imagery to an orthophoto mosaic using a software package such as Pix4D or Metashape. A second software tool such as Global Mapper is then used to interpolate a color for each LIDAR point using this orthophoto. as the colorization source. This is not a true 3DIS data set since the imagery and hence the point colorization is 2D.

4. What is the data quality difference between a True View 515 3DIS and a LIDAR with a “strap-on” camera?

Most strap-on systems do not have the full hardware support to derive synchronized Exterior Orientation of the camera(s) from the POS. In addition, they typically have you colorize point clouds from an orthophoto created from the camera images. The result is 2D rather than 3D colorization of the point cloud. This happens because an orthophoto cannot represent more than one elevation point for each X, Y position.

If a tree limb hangs over a road, a 3DIS will have correct colorization for a road point as well as a tree point (or points, for that matter) directly above the road point (that is, points that share the same X, Y coordinates but have differing Z coordinates). Obviously since images are 2D, the 3DIS algorithm must extract these colorization pixels from different source images.

For example, as the 3DIS passes above the tree, the branches will dominate the image. At a point on down the flight line (or an adjacent flight line), the edge of a different



image will “see” the road surface under the tree. An ortho-based system will attribute every point with the single, top-most color. In our example of a non-3DIS scheme, all points, including the road point, would be colorized with the top-most tree point from the orthomosaic. As you can imagine, this significantly degrades the value of colorization.

## System Specifications, Data Outputs

1. What are the basic specifications of the True View 515?

See Table 1.

**Table 1: True View 515 Specifications**

<b><i>Specification</i></b>	<b><i>Value</i></b>
Control Processor	Google Coral Edge TPU
Laser Scanner	PandarXT-32
Scanner Type	360° rotating
Wavelength	Infrared (905 nm)
Nominal LIDAR Range	80 m @ 20% reflectivity
Field of View (FOV) - Combined	120°
Laser Returns	Up to 2 per outgoing pulse
Number of beams	32
Beam Divergence	2.29 mrad In-track, 1.52 mrad cross-track measured at 80 m range
Pulse Repetition Rate (PRR)	640,000 outbound pulses/sec (640 kHz)
Scanner rotational speed	5, 10 or 20 Hz
Network Vertical Accuracy (typical)	Better than 5 cm, RMSE
Hard surface precision (typical)	Better than 5 cm at 1 $\sigma$
Number of cameras	2
Camera Mounting Angle	$\pm 25^\circ$ off-nadir, cross-track
Camera Sensor	Sony 1" CMOS IMX-183
Sensor size in pixels	20 Megapixels
Shutter	Mechanical
Focus mechanism	Fixed at infinity
Mid Exposure Pulse (MEP)	Electrical
Position and Orientation System (POS)	Applanix APX-15
Data Exchange Format	USB Memory Stick
Power	RRC-2054 48 Wh battery
Operation time per charge	> 1 hr
Operational Temperature Range	0 C to 40 C
Mass	2.15 kg, with battery
Height (sensor only)	175 mm
Length (sensor only)	300 mm
Width (sensor only)	167 mm
Mount	Flat plate or Ronin dove tail



2. What are the individual specifications for the GeoCue Mapping Camera (GMC-1) used in the True View sensors?

See Table 2. The specifications are for each camera. The sensor contains two GMC-1 cameras.

**Table 2: GeoCue Mapping Camera (GMC-1) Specifications**

<b><i>Specification</i></b>	<b><i>Value</i></b>
Camera Model	GeoCue Mapping Camera - 1
Camera Sensor	Sony 1" CMOS IMX-183
Camera Sensor pixels – In-track	3,648
Camera Sensor pixels – Cross-track	5,472
Pixel size	2.399808 micron
Focal Length	10.6 mm (nominal) – equivalent to 28 mm when compared to a 35 mm DSLR
In-Track FOV	44.8°
Cross-Track FOV	63.6°
Shutter	Mechanical
Aperture	$f/2.8 - f/11$ , multistage iris
Mid Exposure Pulse (MEP)	Electrical
Position and Orientation System (POS)	Applanix APX-15
Data Storage	SD Card
Interface	USB

3. What are the dimensions of the True View 515?

See Figure 2 below.

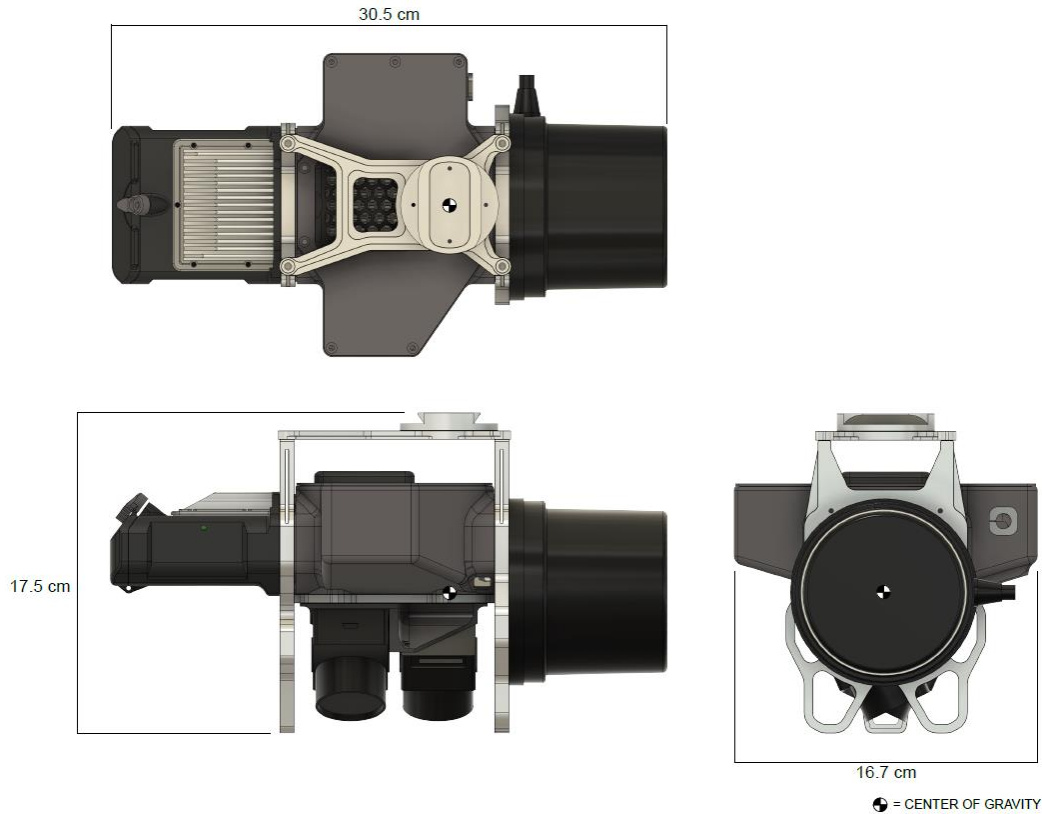

**Figure 2: True View 515 dimensions with CG**

#### 4. What are the *base* data outputs of the system?

We term *base* data fundamental products that feed analytic workflows. The True View 515 post-processing software, True View EVO, produces:

- 3D monochromatic point cloud from the geocoded LIDAR data
- Individual images from the dual cameras. These images are fully “geocoded” with the precise location (X, Y, Z) and orientation (pitch, yaw, roll) from the Position and Orientation System (POS). They can flow directly into image to point cloud software such as Pix4D, Metashape and Context Capture.
- Colorized 3D point cloud – LIDAR points colorized by ray tracing each point into the source images. These data are in LAS 1.4, point data record format 7.
- True Ortho mosaic (requires separate photogrammetry software) – This is a color “true” ortho mosaic constructed by combining a surface model constructed from the LIDAR point data with images from the dual cameras. You can choose the surface model to be used (ground, first surface, etc.). We recommend you purchase Agisoft Metashape to complete this portion of processing

5. What *derived* products can be produced by True View Evo software?

*Derived* products are what the name implies – analytic data derived from the *base* True View 515 products. These are generated using workflows and tools within True View EVO. Examples of derived products include:

- Classified ground model – 3D LIDAR points that represent bare earth. These are generated using both automatic and manual editing tools in True View Evo
- Automatically derived planar surfaces such as building roof prints
- Topographic contours
- Automatic and manual digitized stockpile boundaries (“toes”)
- Volumetric analysis such as stockpile volumes and cut/fill computations
- Profiles and cross sections
- Automatic rail extraction tools (classified rail points, vectorized center line)
- Automatic power line extraction tools (classified wire points, vectorized catenaries)
- Gridded elevation models derived from ground points and first surface points

In addition to the above, True View Evo supports *feature-constrained* (“breakline enforced”) modeling. This allows creation of surface data that is constrained by features such as water body boundaries, edge of pavement, downstream flow, retaining walls and so forth.

## **Positioning Strategies and Accuracy**

### 1. What is a Position and Orientation System (POS)?

The laser scanner in a 3D imaging sensor (3DIS) provides the time a pulse is emitted, the angle with respect to the scanner and the range to the target. In order to deduce where in “object” space this pulse made contact (ground, tree, building, etc.), the position (X, Y, Z) and orientation (pitch, yaw, roll) of the sensor platform, with respect to time, must be known. A Position and Orientation System (POS) is a device that provides a high frequency set of raw measurement from which the position (X, Y, Z) and orientation (pitch, yaw, roll) of the system can be deduced in post-processing software. The hardware comprises a Global Navigation Satellite System (GNSS) antenna and receiver for position and a gyroscopic-type device to deduce angular rates of rotation. The POS also contains accelerometers to measure rates of linear velocity changes.

Post-processing software consumes these raw measurements and outputs a trajectory. This trajectory contains tuples of information that include the time, X, Y, Z, Pitch, Yaw, Roll and additional information that is used to solve for platform position. This trajectory is combined with laser range, angle timing and other data within True View EVO to “geocode” the point cloud.

### 2. What impact does quality of the POS solution have on overall system accuracy?

Unless ground truth (Ground Control Points, GCP) are introduced, the accuracy of the POS sets the maximum achievable accuracy of the system; POS accuracy is *critical* to system performance.

### 3. Why did you select the Applanix APX-15 as the POS for the True View 515?

As noted above, the accuracy of the Position and Orientation System (POS) sets the upper bound for the accuracy of the system (sans GCPs). Applanix, a division of Trimble, has been building high quality POS since the early 1990s. Over these many years, they have become the world’s leading experts on POS technology. We could probably have saved some expense on the True View 515 by selecting a lesser system or integrating our own from piece components. However, our aim was to build a no compromise utility level 3D imaging sensor. Using proven technology from Applanix answers that demand in the POS area of system design.

In addition to providing technology, Applanix is a development partner. As we encounter various positioning phenomenon, they work with us to find the appropriate

solution. For example, Applanix worked with us to develop appropriate initialization maneuvers for the True View 515. They provide backup support to GeoCue when we encounter “odd” positioning problems.

Finally, Applanix is a business partner. They worked very closely with us to enable the novel True View Subscription business model.

#### 4. What Global Navigation Satellite System (GNSS) positioning options are available?

The GNSS portion of the POS solves for position (X, Y, Z). Three positioning options are available with the True View 515 (note that certain processing options require True View Points):

- Single Base – This is the most common positioning strategy. A single local base or a Continuously Operating Reference Station (CORS) is used as a base station. We recommend setting a local static base station for achieving highest project accuracy.
- Applanix SmartBase – This option (where available) uses a virtual static base station scheme for referencing. It allows you to achieve high accuracy without the need to set up a local base station.
- Trimble PP-RTX – This is a precise point positioning (PPP) modeling approach delivered via a network of Trimble modeling stations. It allows global operations without a base station.

All accuracy specifications for the True View 515 assume a local base station.

#### 5. Which GNSS Constellations are used by the True View 515?

The APX-15 Position and Orientation System (POS) and supplied GNSS antenna simultaneously supports:

- (NAVSTAR) Global Positioning System (GPS - USA)
- GLONASS (Russia)
- BeiDou (China)
- Galileo (European Union)

#### 6. What are the base station requirements for the True View 515?

The minimum requirement base station must include:

- Static observations recorded to some media
- Dual frequency L1/L2
- Ability to transform the observation file to RINEX format, version 2.11 or later



True View 515 positioning is always determined using a post-processing workflow. For this reason, the base station does not need to be equipped with a radio. Nearly any high-quality base component of a survey-grade RTK kit will work just fine. For information regarding a specific base station, please contact us.

#### 7. What is the vertical Network Accuracy of the True View 515?

Network Accuracy (sometimes erroneously called “Absolute” accuracy) is the measure of how well data compare to a reference such as a base station location. We specify the network accuracy of the True View 515 as better than 5 cm, Root Mean Square Error (RMSE), prior to any data adjustment (e.g. without the introduction of ground control). This is the accuracy relative to the reference.

#### 8. How do you measure Network Vertical Accuracy during testing?

We set a pattern of ground control targets and measure their locations using real time kinematic (RTK) survey gear. We solve the location of the base station using the National Geodetic Survey (NGS) Online Position User Service (OPUS). Using True View EVO (the post-processing/analytic software included with the True View sensor), we conduct a vertical accuracy test compliant with the American Society for Photogrammetry and Remote Sensing (ASPRS) Accuracy Standards for Digital Geospatial Data. This test essentially measures the average absolute difference between a surface in the LIDAR point cloud and the check points. The summary measurement is termed the Root Mean Square Error (RMSE). This test is conducted using positioning from the POS only; no ground control points are included.

#### 9. What is “Hard surface” precision?

Hard surface precision is a measure of how far LIDAR points deviate, in the perpendicular direction, from a flat, hard surface such as pavement (see Figure 3). True View EVO (the software bundled with each True View sensor) includes a tool for conducting this measurement. The tool automatically finds the orientation of the planar test surface, so it is not necessary to choose a horizontal surface. The precision is specified as the one standard deviation value (i.e.  $1 \sigma$ ) from the surface.

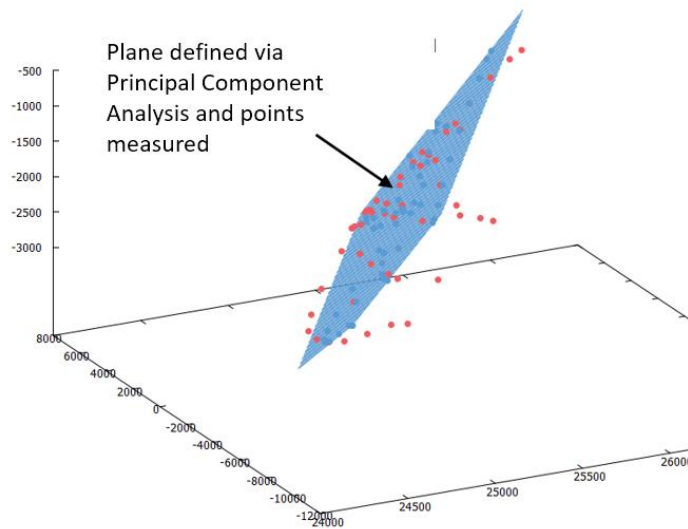

**Figure 3: Measuring hard surface precision**

10. What is the precision of the True View 515?

Typically 4 cm or better, at one standard deviation ( $1 \sigma$ )

11. Can the accuracy of the system be improved by using a post-processing geometric correction software application?

Generally, yes. If you are not satisfied with the airborne direct geopositioning solution, you can use an application such as TerraMatch (software and training available from GeoCue) to refine both the swath to swath relative accuracy and/or the network accuracy of the solution. Ground Control Points are required to improve the network accuracy.

## **Sensor Calibration**

### 1. What is True View 515 sensor calibration?

Sensor calibration (a bit of a misnomer) is the process of measuring a set of parameters that are used in post-processing to accurately convert raw sensor measurements such as time, angle, sensor range and so forth to accurate points/images in object (“ground”) space. Examples of parameters (this list is not all-inclusive) include:

- Timing phase of rotational encoders
- Offsets between the various sensing components of the system (GNSS antenna, laser scanner, POS, cameras, etc.). These are commonly termed “lever arms”
- Orientation of sensors relative to a common sensor coordinate system. This is sometimes referred to as “bore sight” correction.
- Camera intrinsic parameters such as true focal length, radial/tangential lens distortion, principle point offset and so forth (camera Interior Orientation or IO)

### 2. How are True View 515 sensors calibrated?

True View 515 Factory Calibration is a four(five)?-step procedure:

- Sensors undergo laboratory checks for correct offsets and mounting
- The Sensor is flown to perform magnetic calibration; a magnetometer is used to provide initial heading estimates when post-processing sensor data
- A second flight is performed over a test range using a special calibration flight pattern of crossed and overlapping flight lines
- Several software programs are used to fully characterize every sensor parameter. This process is more complex for a 3DIS than a traditional LIDAR since we must simultaneously reference/calibrate two cameras and the laser scanner
- A final “mission” flight is performed over our signalized test range using a different pattern and altitude. Ground Check Points are used to ensure the overall 3DIS is within specification

Results of the calibration are encoded in a sensor-specific calibration file.

### 3. If I use several True View sensors, how can I be sure the correct calibration data are being used in post-processing?

Calibration files are tagged with the unique serial number of the True View sensor. The flight data file from a mission file (a “Cycle” file) is imbedded with this sensor-unique serial number when the file is written to the USB Memory Stick (UMS). During post-





processing, the serial number of the calibration file is compared to the serial number embedded in the Cycle data.

All calibration files are stored in True View Reckon (our Amazon Web Services, AWS, hosted True View repository). This repository is checked when you are doing True View sensor post-processing, alerts you if the wrong calibration file is staged and downloads the correct data file.

4. Is there a fee for storing calibration files in True View Reckon?

No. This service is part of your True View maintenance benefit.

5. How often will my True View 515 need to be calibrated?

There are too many variables to give a firm answer. Calibration is affected by how often you fly, how much shock the sensor has been subjected to and so forth. We provide procedures within True View EVO (the included post-processing software) that will provide indications of the need for a new calibration.

6. Do I have to return my True View sensor to GeoCue for calibration, if needed?

No, we will provide you with instructions on flying a calibration over a suitable site. You will send us the Cycle file from the sensor (via FTP posting) and we perform the calibration. You will not need to take any action on your end with the new calibration. We post the file to True View Reckon. It is automatically downloaded when you do your next post-processing session.

7. Is there a charge for post-delivery system calibration?

Yes, there is a fee for post-delivery calibration.

## Mission Characteristics

### 1. What is the recommended flight speed for the True View 515?

Flight speed depends on the type of collection. The slower the forward speed of the aircraft, the higher the point density. We fly most general data collection projects at 5 meters per second (m/s).

### 2. What is the recommended flying height for the True View 515

For any airborne sensor, flying height is a compromise between resolution/accuracy and efficiency. In most cases, the lower you can fly, the higher will be the resolution and accuracy of the data. We will be creating a separate white paper on mission planning with the True View 515. A rough set of rules for the nadir above-ground level (AGL) is:

- Rough site work (volumetrics, 2' contours) – 90 m
- General topo work, general purpose flights – 75 m
- Dense vegetation – 60 m with double coverage at right angles (e.g. fly the project N-S and repeat E-W)
- Transmission lines – 60 m from phases

### 3. What is the recommended swath overlap?

Swath overlap is used for two purposes:

- To provide increased point density (for example, in heavy vegetation)
- To provide “differencing” areas to allow post-process geometric correction in products such as TerraMatch

If you are not facing one of the above tasks, we recommend sufficient overlap to ensure there are no data gaps between flight lines. As a general rule of thumb, we plan a 30% overlap after accounting for off-nadir angle clipping.

### 4. What is the recommended scan angle clipping?

For general topographic mapping, accuracy decreases with increasing scan angle. This is because the laser spot on the ground elongates in the cross-track direction due to its oblique intersection with the ground. This causes some ambiguity in the range determined by the system. The sensor nominally (this can be changed in a mission file) collects  $\pm 60^\circ$  from nadir. During both post-process geocoding and within True View Evo, this angle can be reduced. For mission planning, we recommend  $45^\circ$  for low accuracy



projects, 40° for general topographic mapping and 30° for highest accuracy. Obviously you need to plan flight line overlap based on the clipping strategy.

5. What is the ground point density of the True View 515?

For a nominal flight of 75 m above ground level (AGL), scanner rotational speed of 10 revolutions per second, clipping data at  $\pm 45^\circ$  from nadir and a flight speed of 5 m/s, the theoretical point density averages 210 first return points per  $m^2$ .

## **sUAS (drone) Platforms**

### 1. What drone platform do you recommend for the True View 515?

Unless prohibited by regulations (e.g. DOD work), we recommend the DJI Matrice 600 Pro (M600). It is a very reliable and easy to fly platform that is quite economical. It uses 6 smaller batteries rather than one or two large batteries. This allows the batteries to be transported in commercial airlines as carry-on luggage.

We also support the DJI M300 though our personal preference, when using DJI, is the M600 Pro.

### 2. How is the True View 515 attached to the M600 Pro?

We use the Ronin gimbal anti-vibration mount. This allows the True View 515 to be mounted to the M600 using a quick-attach dovetail mount. If you already own an M600 Pro with a Ronin Gimbal, you will not need any additional mounting hardware. If you do not have the Ronin gimbal, you can purchase a True View 515 M600 Pro mounting kit from us.

### 3. What electrical connections are required between the drone and the True View 515?

None. The True View 515 is completely independent from the drone, from an electrical point of view.

### 4. Can the True View 515 be used on a drone other than the DJI M600 Pro?

Certainly. We have had customers mount True View sensors on a variety of platforms. The platform requirements are:

- Must be capable of flying slow enough to conduct LIDAR operations. We would say at least down to 4 m/s
- Must be capable of carrying a payload of 2.25 kg
- Must have enough clearance between the underside of the drone and the ground to accommodate the True View 515
- Must have landing gear that are clear of the field of view of the sensor (for example, retractable)



5. Does GeoCue offer off-the-shelf mounting kits for drones other than DJI?

Yes. We have standard kits for:

- Inspired Flight
- Harris H6
- BFD
- FalconUAV

6. Does GeoCue offer assistance with mounting the True View 515 on platforms other than those previously mentioned?

Yes. We offer everything from 3D model diagrams to full consulting and manufacturing services (we have our own machine shop). Mounting the system is quite straightforward so long as the drone meets the general requirements of the previous question.



## **True View Purchased Systems**

1. What is included with a purchased system?

Please see the “What’s in the box” FAQ.

2. How do I access SmartBase and PP-RTX referencing modes with a purchased system? Do I have to purchase an annual subscription?

An annual subscription is not required. All three supported reference models can be “Cloud” accessed during post-processing (the POSpac processing step). The charge is based on minutes the sensor is in motion (kinematic minutes or “kinmin”). The charge depends on the number of kinmin already used within the current month. Charges are in “True View Points” (TVP). Note that one would not normally use the cloud-based Single Base option under a Purchased System processing flow since a desktop version of POSpac is included with the system. The option is provided just in case your desktop software is not available or is in use by another user.

**Table 3: Positioning Service Costs under the Purchased System Model**

<b>Mode</b>	<b>0 – 500 KinMin (in current month)</b>	<b>501 – 1,000 KinMin (in current month)</b>	<b>1,001 and up (in current month)</b>
Single Base (if using cloud option)	0.85 TVP	0.74 TVP	0.60 TVP
SmartBase	1.15 TVP	1.00 TVP	0.85 TVP
PP-RTX	2.50 TVP	2.30 TVP	2.10 TVP

3. Are there any mandatory fees for use of the system beyond the purchase price?

No. The only use fees are if you decide to use cloud-based processing options for POS post-processing. The most common (and recommended) POS reference mode is a single, local base station. Your desktop version of POSpac is used in this mode and does not incur a processing fee.

#### 4. What is the maintenance policy for a Purchased system?

The first year of comprehensive maintenance for hardware and software is included in the purchase price. While under active hardware maintenance, all system repairs (except where caused by crash or abuse) and firmware updates are covered at no cost. You will be responsible for two-way shipping expenses to our Huntsville, Alabama USA facility if your unit requires a “return to factory” repair.

Software maintenance includes all software fixes and feature updates as well as email technical support. All software included with the system is covered.

After the first year, hardware maintenance is optional. Software maintenance is mandatory (certain elements of your software will cease to function if you do not have an active maintenance agreement). You have two options for continuing maintenance:

1. Full system maintenance, including both hardware and software. These agreements are issued in 1-year increments.
2. Software-only maintenance agreement. Hardware would be repaired on a per-incident basis.

#### 5. What is “per-incident” hardware repair?

Per-incident hardware repair is an option if you elect not to extend your hardware maintenance following the one-year bundled hardware maintenance period of the True View sensor. Per-incident repair follows these steps:

1. You contact True View Support (via email) with a description of the problem
2. GeoCue determines the type of problem
3. If it is field repairable (e.g. cable replacement, etc.) we will provide you with a cost for parts and consulting.
4. If the problem requires a return to factory, you ship (at your expense) the sensor to our Huntsville, Alabama USA location.
5. For a flat fee, we will diagnose the problem and send you a firm fixed price for the repair. We can optionally bundle in the return shipping cost.
6. If you decide to proceed, we will repair your system, fight test, calibrate and return to you.
7. If you elect not to proceed with the repair, we will return your unit to you (you must pay the return shipping)



## True View Subscription Models

### 1. What are the details of the True View 515 subscription model?

There is a monthly subscription fee that depends on the length of the subscription (1 month, 3 months or 12 months) - the longer the commitment, the lower the monthly fee. Each month, 3,250 *expiring* True View Points (TVP) are issued, regardless of the subscription length. These points expire one month after they are issued.

Using a True View sensor under the subscription model is based on the minutes of flight time of the sensor (time the sensor is in motion). We term these kinematic minutes or “kinmin” for short. Kinmins are paid for with True View Points. The cost, in True View Points, for a kinmin depends on the processing strategy (single base, SmartBase or PP-RTX) and the cumulative kinmin already changed in a month (cost breaks occur at 500 and 1,000 monthly cumulative kinmin).

Additional True View Points can be purchased if the monthly allocation is not sufficient to cover your flight needs. Explicitly purchased True View Points do not expire.

### 2. How many minutes of processing will the monthly allocation of 3,250 True View Points “buy”?

It depends on the post-processing mode. The standard processing mode is to use a local base station. Under this processing model (single base), 3,250 True View Points will “buy” 500 kinmin (500 minutes of in-motion time) at their most expensive level (6.50 True View Points per kinmin). The exact charge per kinmin in True View Points is listed in Table 4. Note that these charges are True View Points per kinematic minute, not dollars. The cumulative kinmin counter is reset each month on the anniversary day of the sensor.

**Table 4: Kinmin Cost in True View Points**

<b>Mode</b>	<b>0 – 500 KinMin TVP/kinmin</b>	<b>501 – 1,000 KinMin TVP/kinmin</b>	<b>1,001 and up TVP/kinmin</b>
Single Base	6.50	3.50	1.75
SmartBase	8.50	4.25	2.50
PP-RTX	10.50	6.50	4.00



3. What would be the cost to fly a True View 515 Subscription system for 30 flight hours in 1 month using only a Single Base reference system?

30 flight hours equates to 1,800 minutes of sensor in motion time or 1,800 kinmin. If you examine the True View Point (TVP) fee structure of Table 4, Single Base row, you will see the graduated fees:

- First 500 kinmin = 6.50 TVP/kinmin
- Next 500 kinmin = 3.50 TVP/kinmin
- Above 1,000 kinmin = 1.75 TVP/kinmin

Thus the total cost for 30 hours of flight time, all with Single Base processing mode, is computed as:

500 kinmin × 6.50 TVP/kinmin	= 3,250 TVP
500 kinmin × 3.50 TVP/kinmin	= 1,750 TVP
800 kinmin × 1.75 TVP/kinmin	= 1,400 TVP
Total	= 6,400 TVP

The subscription includes 3,250 TVP per month so 3,150 (6,400 – 3,250) additional True View Points would need to be purchased.

4. How do I purchase additional True View Points?

True View Points can be purchased on-line from the True View Reckon store by credit card or, if you have a credit account with GeoCue, by charging to your account.

5. Do purchased True View Points expire?

No.

6. Are Purchased True View Points refunded at the end of a Subscription?

No. However, they do not expire and can be used for any transaction that is enabled for True View Points

7. How many acres can be covered with one kinmin?



This depends very much on the type of site, flying height, desired flight line overlap and so forth. For a typical topographic project flown at 60 m, you will average at least 2.5 acres per kinmin. We give a rough estimate that you will be able to fly 50 sites per month of 20 acres each without needing to purchase additional kinmin.

8. Are sensors provided under the Subscription program new?

No, they are not. However, each sensor is tested and calibrated prior to being sent to a new customer.

9. What happens if a sensor under the Subscription program fails?

We will work with you to ensure that the sensor cannot be repaired remotely (e.g. an operator error, firmware issue, etc.). If it cannot be remotely repaired, we will ship you a replacement. You will ship the failed sensor back to us. Please note that we immediately ship; we do not wait to receive the failed sensor. There is no additional charge for this replacement.

10. Is all software included in the Subscription?

Yes. You will run POSpac in the “cloud” (in fact, this is the step at which kinmin are metered). The desktop version of True View Evo is supplied.

11. How do I attach a True View 515 Subscription unit to my drone?

If you are flying an M600 Pro, we will provide a mounting kit with your Subscription at no additional charge. This kit must be returned at the end of your Subscription. If you need to use a different drone, please contact us for advice on mounting. We have been involved in mounting the True View 515 on a variety of platforms.

12. Does the Subscription include the drone?

No. However, we are an authorized DJI Enterprise reseller and will be more than happy to sell you an M600 Pro. If you insist on renting a drone, there are several companies in the USA who rent M600 Pro platforms. However, do a careful cost analysis – it is nearly always more cost effective to purchase the M600 Pro if your usage will exceed more than a few weeks.

13. Do you rent drones?

No.

14. Is technical support included with the Subscription?

Yes, email technical support is included for the workflow steps running from mission planning through producing a colorized point cloud. Technical support is not included for generating *derivative* products. However, paid web training can be purchased for this segment of the workflow.

15. Am I responsible for loss of the sensor under a Subscription?

Yes. You are responsible for loss or damage to the sensor, regardless of cause. We strongly recommend that you carry damage insurance on the sensor.

16. Is insurance on the sensor mandatory for Subscriptions?

While it is strongly recommended, it is not mandatory.

17. What is the replacement cost of a True View 515 subscription sensor?

We assess the cost to repair the sensor and inform you of this cost. If the sensor is a total loss (stolen, lost, damaged beyond repair), we will assess you a flat cost of US \$40,000.00.

18. Is software maintenance included in the subscription fee?

Yes.

19. The Subscription program seems too good to be true. What is the catch?

There is no catch or hidden fees. Of course, if you consume more than 3,250 True View Points per month (500 kinmin per month in single base processing mode), you will need to purchase additional True View Points. Thus if you are a very heavy user, you will want to compare the ownership model to the Subscription model.

## **Training**

### 1. Is Training mandatory prior to purchasing a True View 515?

No. However, if you do not attend our free Huntsville-based training or purchase on-site training, we cannot supply “email training.” Our technical support is designed to assist you with specific operational issues once you have learned to use the system.

### 2. What is the cost of your monthly Huntsville-based “bootstrap” training?

The two-day bootstrap training offered at our Huntsville, Alabama USA office is included in your Subscription cost. There is no additional charge.

NOTE: During the current COVID-19 pandemic, this training is being conducted online.

### 3. What is taught in the two-day bootstrap training?

The two day “bootstrap” training takes you from mission planning through exporting a colored point cloud (and, if you desire, geocoded images). The general topics include:

- Mission planning considerations –
  - coverage
  - reference strategy
  - ground control/check points (GCP)
  - safety planning
- Planning a mission
- Flying a mission (we will fly at our GeoCue test site, weather permitting)
- Field checks
- Creating a True View project
- POS processing
- Defining flight lines
- Geocoding LIDAR (creates standard, monochromatic point cloud)
- Colorizing the point cloud (creates RGB colorized point cloud)
- Assessing accuracy
- Debiasing the point cloud
- Geocoding images
- Exporting data
- Selected topics, time permitting, in derivative product processing in True View EVO

## True View Ecosystem

### 1. What is the “True View Ecosystem”?

The True View “Ecosystem” is what we have labeled our entire collection of hardware, software and services for small Unmanned Aerial Systems (sUAS or drone) that are being integrated into a total workflow solution.

### 2. What are the components of the True View Ecosystem?

Individual components of the Ecosystem include:

- True View 3DIS hardware
- True View EVO Processing software
- True View Reckon (AWS-hosted “cloud-based” services)
- True View Services
- True View Accessories

### 3. What is the long-term vision for the True View Ecosystem?

The longer-term goal of the overall True View ecosystem is to connect sUAS sensors, software and services to increase the value over using these components in isolation. Some elements are already integrated such as:

- Managing True View Subscriptions
- Managing sensor calibration files
- Providing a repository and viewing tools for your project data

As we move forward, many more services will become available via True View Reckon. A near-term goal will be the management of sensor firmware updates.

### 4. Will additional True View sensors be forthcoming?

Yes. In the first half of 2021 we will release:

- True View 250 – A dual camera system (no laser scanner) with direct geopositioning specifically designed for the DJI Matrice 200 drone series
- True View 635 – A Riegl miniVUX3 system using the APX-15 as the Position and Orientation System. It will include the same dual camera setup as the True View 515. This sensor is a 300,000 kHz version of the True View 615.



- True View 640 – The same base system as the True View 635 but will use the Applanix APX-20 Position and Orientation System. This sensor is a 300,000 kHz version of the True View 620.

We are continuously evaluating technology and our customer needs. We will use this input to inform our design decisions as we move forward in time.